

Ready to ROLL

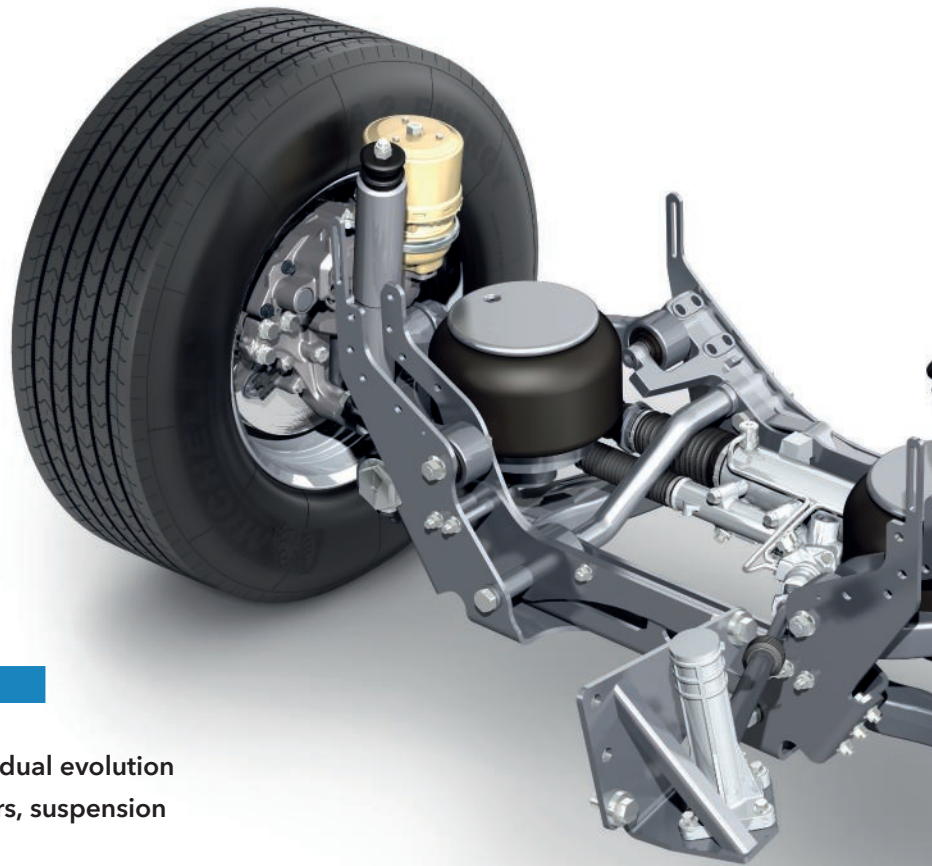

Truck running gear has seen mostly only gradual evolution over the years, but, as John Kendall discovers, suspension and steering systems are on the move

Truck chassis – two parallel rails with cross members – have survived virtually unchanged for around a century. Semi-elliptic leaf springs are also still widely used, while beam axles and hypoid gears remain the norm. However, newer technologies are making their presence felt – and more are set to come.

In September last year, the EU launched a three-year research project, dubbed optiTruck, designed to reduce the impact of heavy-duty vehicles on greenhouse gas emissions by at least 20%. Based around a 40-tonne gcw vehicle, trialled technologies include predictive and intelligent powertrain controls, as well as calibration methods. Also included are ITS (intelligent transport systems), covering communications between vehicles and traffic management systems.

Two vehicles will be used for trials: one equipped with current state-of-the-art equipment to produce baseline data; the second with proposed powertrain control and ITS systems. Information to date suggests that improvements will centre on: adapting chassis and powertrains to match dynamic vehicle loads and aerodynamics; predictive management and auxiliary system

controls; and monitoring surrounding vehicle driving patterns.

Meanwhile, at last September's IAA Hanover show, Jost – which began manufacturing and distributing trailer axles engineered by Mercedes-Benz in January 2015 – displayed several developments. Drawing on the company's durable compact axle (DCA) range, for example (which incorporates axle tube, trailing arm, brake flange and axle journal in a single unit), the company launched its DCA Airmaster.

AIR SUPPLY

Claimed to be the only trailer axle in the world that can store compressed air (40 litres) within its housing for both brake and air suspension circuits, it eliminates separate air tanks. Jost says this can cut weight by up to 50kg, while also freeing up space under the trailer – handy for trailer operations involving ground clearance issues. And it can be fitted with a brake wear indicator.

But the company had more up its sleeve – also launching its DCA SteerMaster trailer steering axle for wide single tyres. This 9-tonne capacity axle offers steering angles up to 21° for improved manoeuvrability. It can be specified with 300 or 360mm diameter air bellows, and accommodates ride

heights of 225–535mm with 19.5- and 22.5-inch wheels.

Jost also introduced the Weight Optimiser 27, offering weight reductions for its DCA series of trailer axles. The weight saving comes from the use of an aluminium air bellow support bracket, which saves a claimed 9kg per axle, leading to a reduction of 27kgs for a tri-axle semi-trailer. The bracket is designed ideally for use with 300mm air bellows in the Jost DCA series and has been designed for all common trailer track widths. It was designed to handle maximum payloads.

Back on steering, Jost's Tridex division is a specialist, with its latest development an electrically-controlled trailer axle system. EF-S harnesses an angle sensor and self-centring wedge integrated into the trailer kingpin. The firm says it has been designed to enable very low trailer necks, as required for milk and bulk trailers, or those with monocoque construction. The system accommodates neck mounting heights of 60mm, and up to three axles can be steered, allowing trailers to accommodate tight bends while minimising rear swing-out.

Trailers can be steered by remote wireless control, with both in-ratio or crab steering, where the wheels all align.

“Independent suspension puts a twisting moment on the side member, so you then have to brace against that... You have to fit a large tube under the engine”

Martin Flach

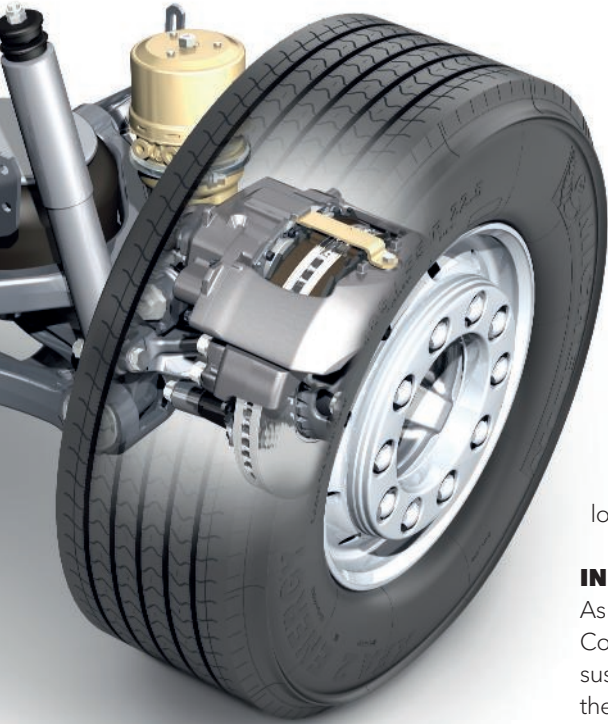

The system uses electrical power, usually from the trailer batteries, charged via the tractor's electrical circuit. It drives an electrohydraulic power pack, which supplies an axle-mounted accumulator to generate the steering angle. Tridac claims benefits include reductions in fuel consumption and tyre wear.

The company is now developing a path-following steering system, said to integrate sensor data used by the electronic controller, enabling the trailer to precisely follow the track of the tractor unit, much like a drawbar trailer. Additional manoeuvrability could make reversing up to loading docks much simpler. Tridac says that, by integrating the system with blind spot sensors and a collision avoidance system, obstacles and people in the driver's blind spots could be

avoided, with the controller steering the trailer automatically.

Returning to suspension, though, Volvo claimed a world first for a heavy truck back in 2012 when it offered independent air front suspension on its new FH. Given that just about every car on the road has the configuration, the benefits - including better ride comfort and improved handling - speak for themselves. But other benefits claimed by Volvo include improved stability and potentially lower ride height.

INDEPENDENT THINKING

As Volvo product manager John Comer said at the time: "Truck front suspensions have been refined over the years but they're still crude by comparison." And he made another point: Volvo's independent front suspension can also be specified with the firm's dynamic steering, which harnesses an electronically-controlled electric motor on the steering shaft to deliver extra hydraulic power assistance at low speeds and to compensate for the effects of side winds and potholes at higher speeds. "This can be fitted to both single and dual front-steer axles and dampens any vibrations coming up through the steering column," comments Comer.

However, just how much these factors matter on a heavy truck is a matter for debate. Handling the forces generated requires considerable chassis bracing, as Iveco

product director Martin Flach explains. "Independent suspension puts a twisting moment on the side member, so you then have to brace against that. Then, exactly where you would want a cross member is where the engine sits, so you have to fit a large tube instead under the engine."

For him, then, it's not easy to see where the cost-benefit ratio works. "We have yet to come up with a business case that says it's worth doing." That said, he does see benefits with technology such as lane keeping support systems. "A lane departure warning system is a good step forward in safety, but linking that to a small motor drive on the steering column - that tends to hold the lane if you are drifting - is relatively easy."

Easy, yes, but Flach worries that operators may well be reluctant to pay the price. "The reality is that, over the years, we've found anything safety-related shows a really low take-up until it becomes mandatory."

What about systems designed to help prevent unevenly distributed loads for trucks on distribution routes with diminishing loads? "That is fairly straightforward," says Flach, explaining that such systems only need inputs from the air suspension system. "The [financial] benefit will be getting the right load on each tyre, leading to reduced rolling resistance and better fuel consumption and tyre wear." 